

# Diamonds – DACs – HP instruments

Koen De Hantsetters (CEO Almax easyLab)



## OUTLINE

Introduction & history

Diamond: types – shapes – selections – quality – cutting - specials

DACs: applications

HP instruments: gasket preparation - pressure calibration

Questions



## INTRODUCTION & HISTORY

Almax easyLab is commercial supplier of high pressure tools and solutions

Merger in 2013 between

Almax Industries

Diksmuide, Belgium  
Diamond anvil polishing factory

easyLab Technologies:

Reading, UK  
DACs & HP instruments

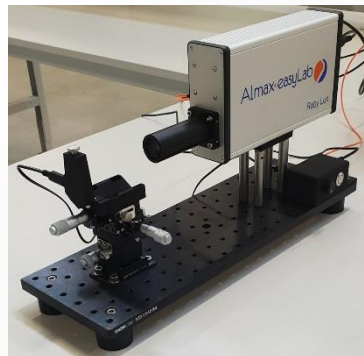

## COMPANY

Production in Diksmuide Belgium

Staff

- 1/2 diamond polishers
- 1/4 engineers/scientists
- 1/4 sales/administration

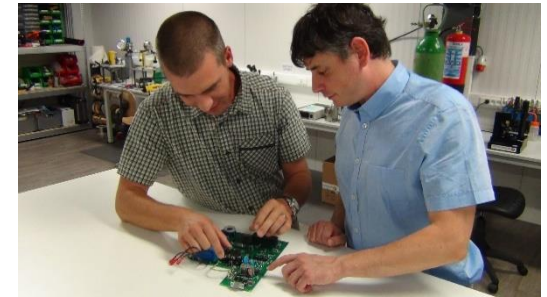

## Diamond types

### NATURAL TYPE Ia

Photoluminescence – X-ray Spectroscopy –  
Electrical – Magnetic – Mössbauer

~ $2 \times 10^3$  ppm of nitrogen – yellow

*“We took a PlateDAC to 285 GPa at Diamond Synchrotron back in Feb. 2016.  
This was with 40 micron culets. The pressure calibrant was Cu.”*



## Diamond types

NATURAL TYPE Ia – Raman (ultra) low fluorescence

Photoluminescence – X-ray Spectroscopy –  
Electrical – Magnetic – Mössbauer –

Raman Spectroscopy & Related Vibrational Techniques

~ $2 \times 10^3$  ppm of nitrogen – white to light yellow



## Diamond types

### NATURAL TYPE IIa

Photoluminescence – X-ray Spectroscopy –  
Electrical – Magnetic – Mössbauer –  
IR Spectroscopy

~1 ppm of nitrogen – white to light brown

Can be made white with an HPHT treatment => became expensive

Only 2% of all natural diamond are type IIa => difficult to find

Most natural type IIa stones are flat and very birefringent => low quality

=> Replaced by type IIac and type IIas



## Diamond types

### SYNTHETIC TYPE IIac

Photoluminescence – X-ray Spectroscopy –  
Electrical – Magnetic – Mössbauer -  
IR Spectroscopy

~1 ppm of nitrogen – white – CVD – max. available height of 2.00 mm

*“We have used your type IIac diamond anvils for X-ray and an infrared experiments. They have been recovered from 90 Gpa without ring-cracks. These diamond anvils are very important to us for the IR absorption measurement since their absorbance in the **infra-red** is much less than the natural ones”*

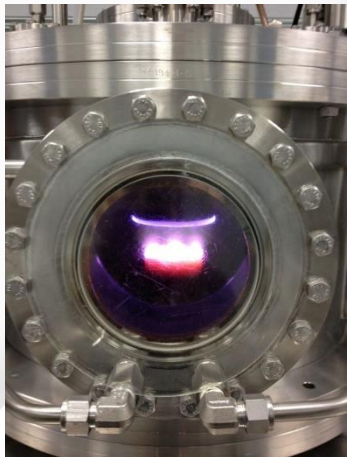
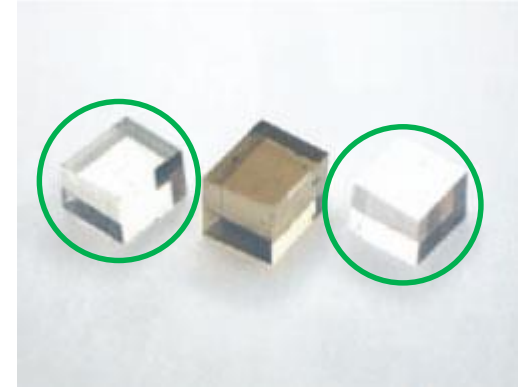



## Diamond types

### SYNTHETIC TYPE IIas

Photoluminescence – X-ray Spectroscopy –  
Electrical – Magnetic – Mössbauer -  
IR Spectroscopy – Raman Spectroscopy &  
Related Vibrational Techniques

~1 ppm of nitrogen – white - HPHT

Anvils readily available up to 4.00 mm and becoming  
more affordable.



## Diamond types

- Single crystal:

type Ib => Ruby fluorescence!?

type IIb => Boron Doped

- Polycrystalline:

PCD => large anvils for neutron work  
importance of quality for less absorptic  
not transparent

NPD => large anvils for neutron work  
for laserheating  
EXAFS (avoiding glitches)  
transparent, became commercially available but  
extremely expensive



## Diamond types evolution

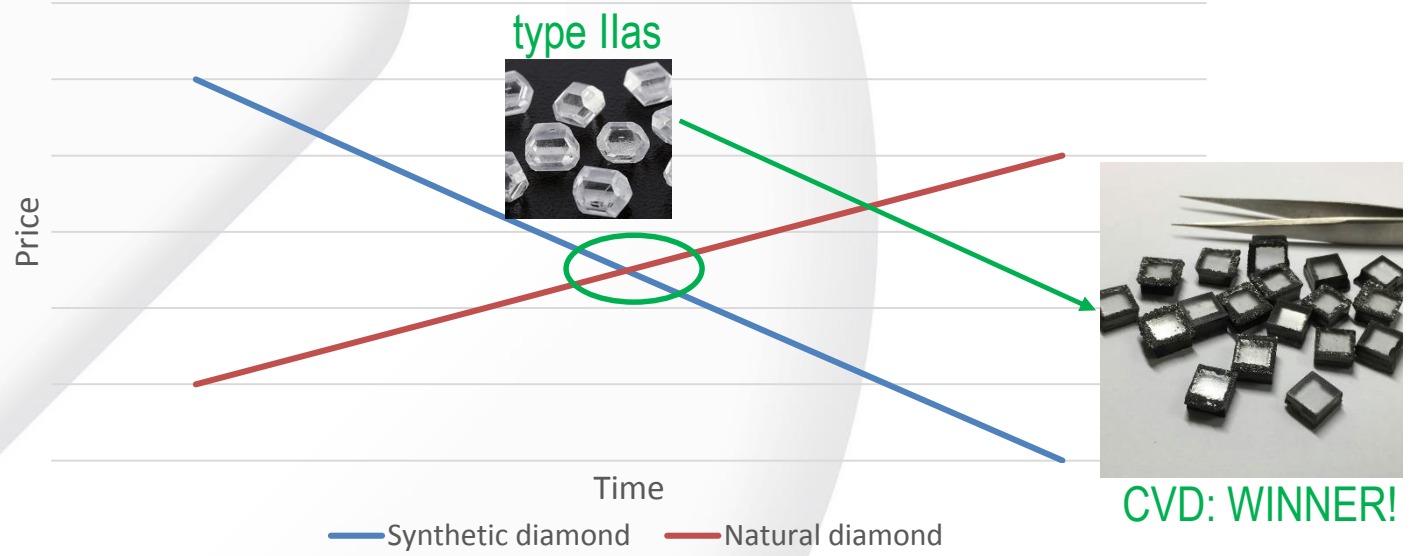

## Diamond shapes

DESIGN:

Boehler-Almax

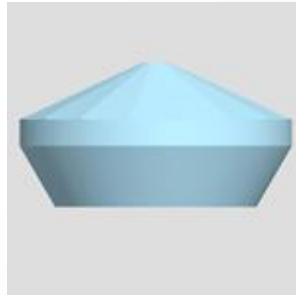

Standard

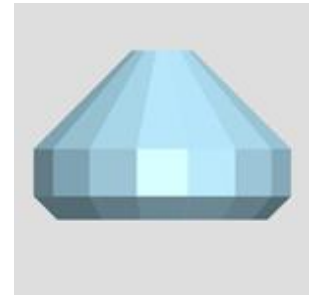

Modified Brilliant Cut

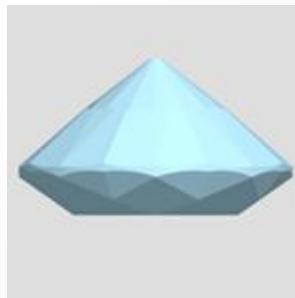

Diacell

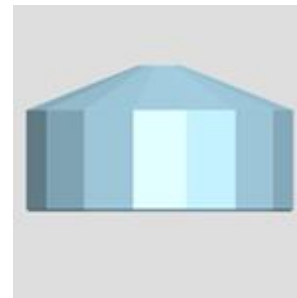

Diamond shapes

DESIGN:

Boehler-Almax

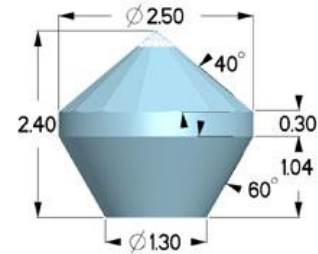

high pressure  
 small aperture  
 low cost

high pressure  
 larger aperture  
 very popular

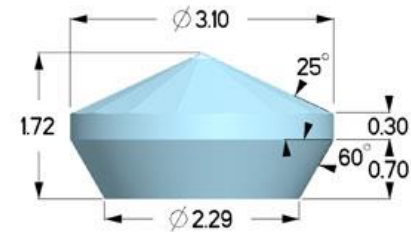

max pressure 50 Gpa  
 largest aperture

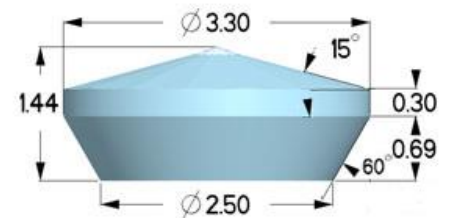

## Diamond shapes

DESIGN:

Boehler-Almax



- + large apertures
- + small anvils => high pressures
- + reduced heights => less beam absorption
- + seats do not break
- ! seat design and precision
- ! default designs, but flexibility possible
- ! Largest aperture today 120°

## Diamond shapes

DESIGN:

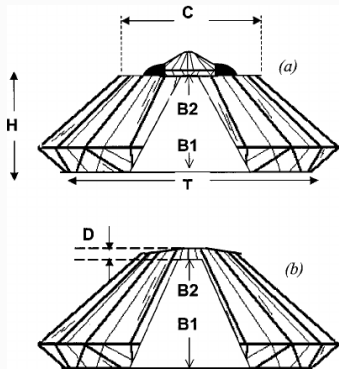

Standard

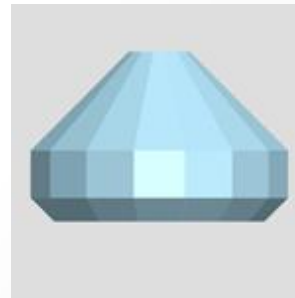

- Anvils smaller than 2.50 mm diameter => girdle ground round
- Type IIac adapted for max. height
- Default designs, but flexibility possible

Type Ia – Standard design – (100)-oriented			
X in mm	Appr Weight		Product code
2.50	0.09		P01003
2.75	0.12		P01004
3.00	0.16		P01005
3.25	0.21		P01006
3.50	0.26		P01007
3.75	0.32		P01008
4.00	0.38		P01009
4.25	0.46		P01010
4.50	0.55		P01011
4.75	0.64		P01012

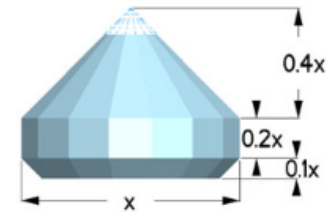

## Diamond shapes

### DESIGN:

#### Modified Brilliant Cut

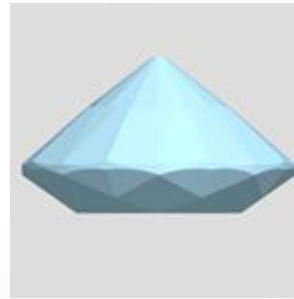

- Starts from brilliant cut gem diamonds
- Available in type Ia only
- (100)-oriented versus randomly oriented

Type Ia – Modified brilliant cut – (100)-oriented				
Appr Weight (carat)	Appr Girdle diameter	Appr Height	Drawing	Product code
0.10	3.10	1.86		P01026
0.15	3.50	2.10		P01029
0.20	3.80	2.30		P01030
0.25	4.10	2.46		P01032
0.30	4.40	2.64		P01033
0.35	4.60	2.75		P01034



## Diamond shapes

DESIGN:

Diacell

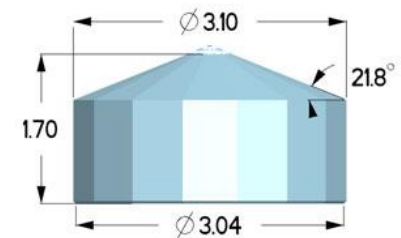
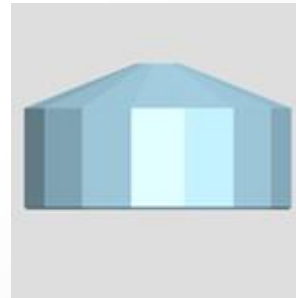

- Tailored for our specifically designed DACs and normally mechanically force fitted in anvil rings.

## Diamond shapes

FACETS:

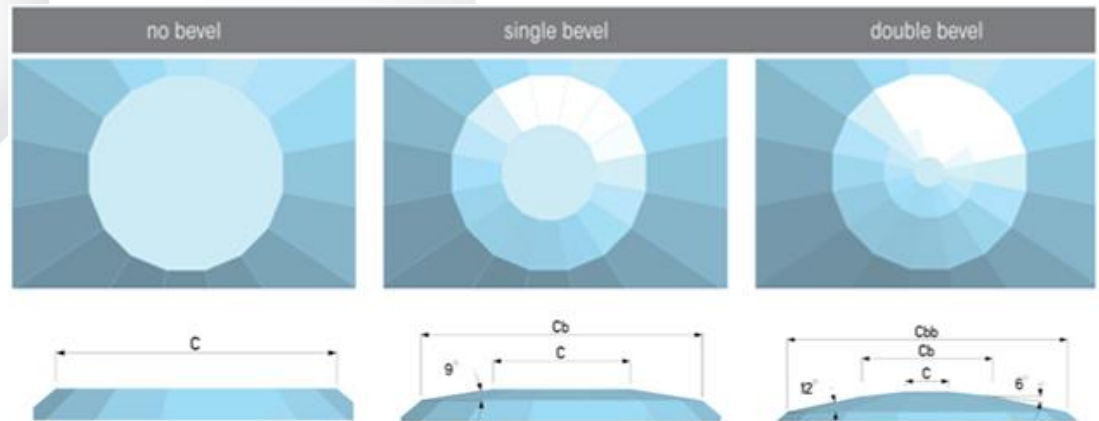

- 8-sided (very rare) versus 16-sided (99%)
- Bevels:
  - for higher pressures (less stress)
  - less risk of damaging the culet during alignment
  - easier to clean the culet
  - when bringing in wires or patterns in the sample chamber

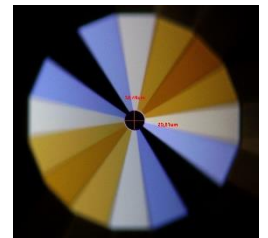
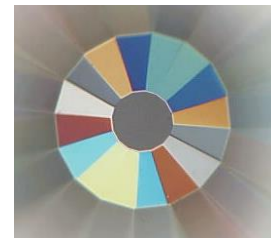

## Diamond shapes

### CULET SIZE:

- Very general and safe guidelines for maximum pressures
- Type Ia Bohler-Almax design, 16-sided, 3.10 mm – 70°

Culet size (µm)	Max.P(Gpa)
80x300	125-150
150x300	100-120
250x300	60-70
250	60-65
300	50-55
350x400	40-50
600	15-20
800	5
1000	1

## Diamond selections

### RAMAN

- The intensity of the two-phonon Raman transition at 2664 cm<sup>-1</sup> is at least 2 times the intensity of the background fluorescence of diamond
- Type Ia (natural): no, ratio of 1.25 or ratio of 2.
- Type IIas (synthetic): ratio of 5 or more...

Second order Raman spectrum of a type Ia diamond anvil without Raman selection

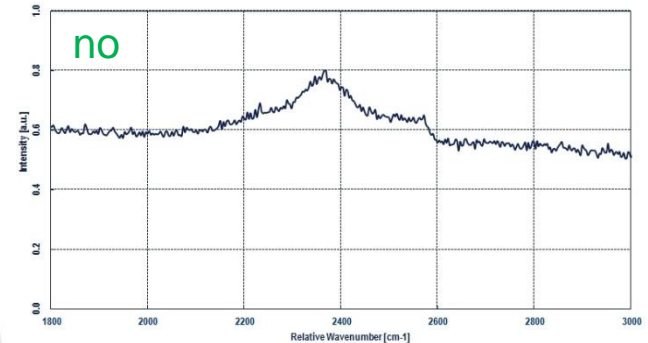

Second order Raman spectrum of a type Ia diamond anvil with Raman ultra low fluorescence selection

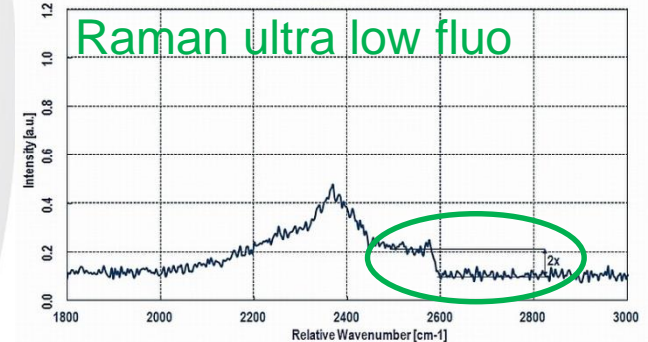

Second Raman spectrum of type IIas diamond anvil

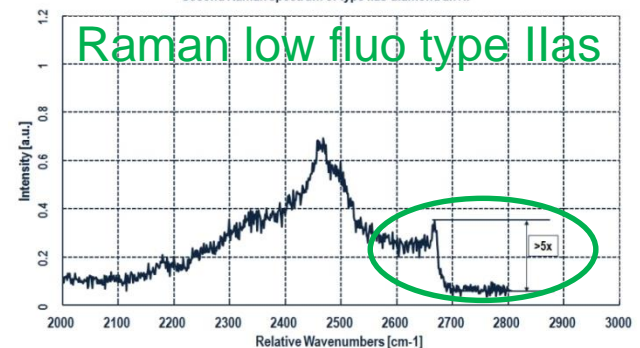

## Diamond selections

### BIREFRINGENCE

- No birefringence selection (default)
- Low birefringence  $< 0.0001$
- Ultra low birefringence  $< 0.00005$

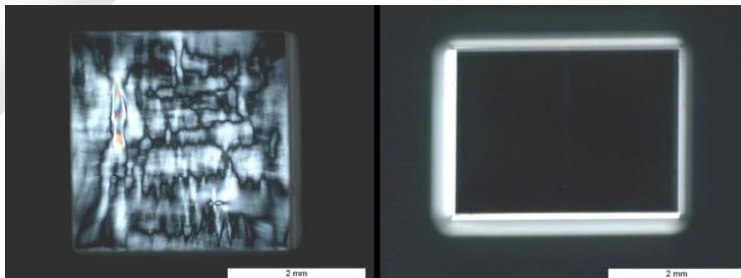

Not acceptable

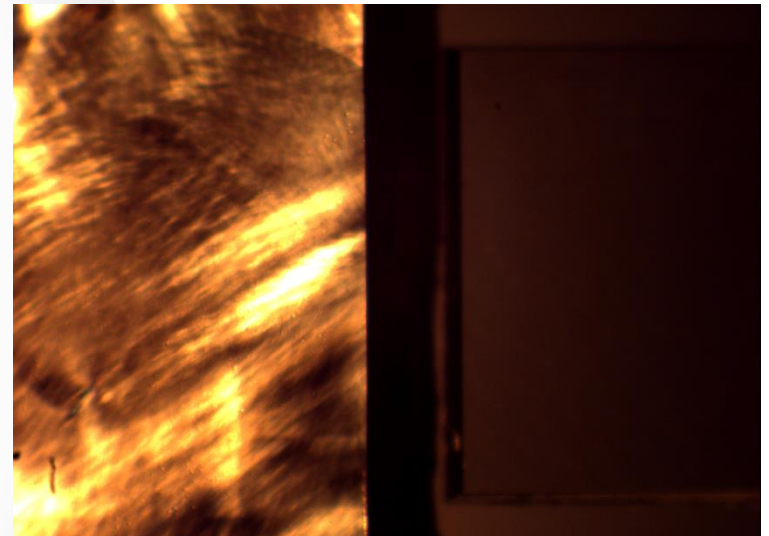

Ultra low  
birefringence

## Diamond quality

### ORIENTATION:

- $< 3^\circ$  off (100) orientation
- Important for the highest strength
- More reliable results when using the Raman edge for pressure calibration

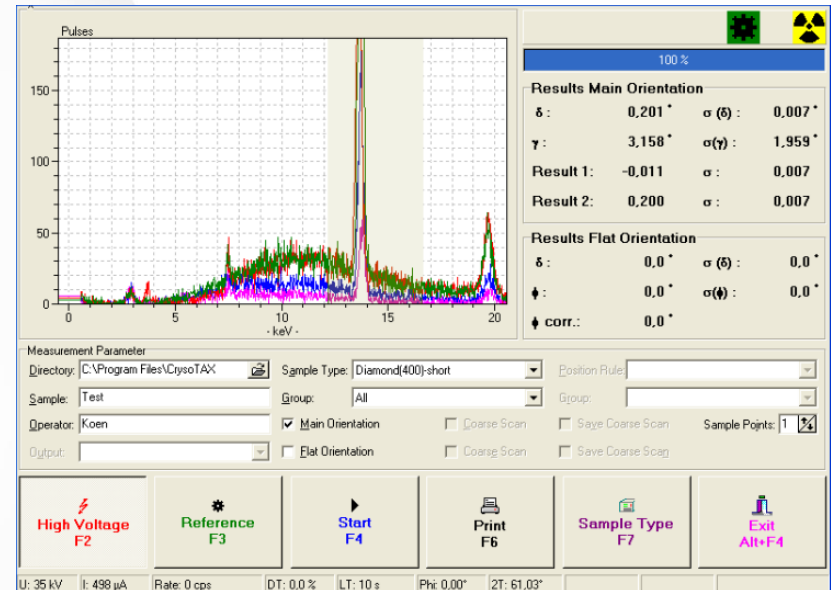

## Diamond quality

### SYMMETRY AND ACCURACY:

- Surface quality of the culet  $R_a < 0.5$  nm, reduced subsurface damage
- Parallelity of culet and table  $< 10'$
- Unbevelled culet:  $\pm 10$   $\mu\text{m}$  – Bevelled culet  $\pm 5$   $\mu\text{m}$
- Centricity of culet  $< 0.02$  mm
- Cone angle  $60^\circ \pm 0.1^\circ$  - Cone roundness  $< 5$   $\mu\text{m}$
- Cone perpendicular to table  $< 0.2^\circ$
- ...

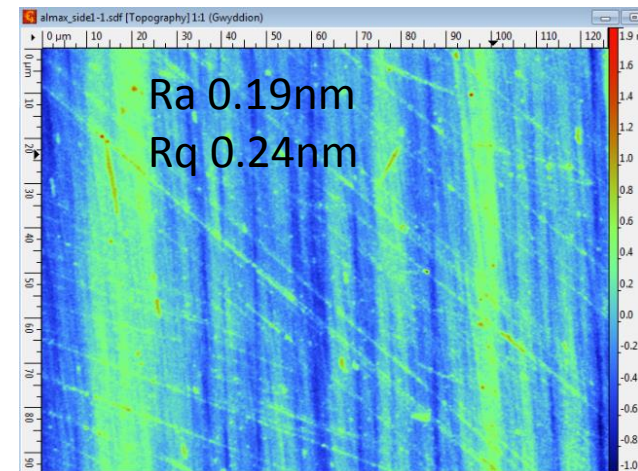
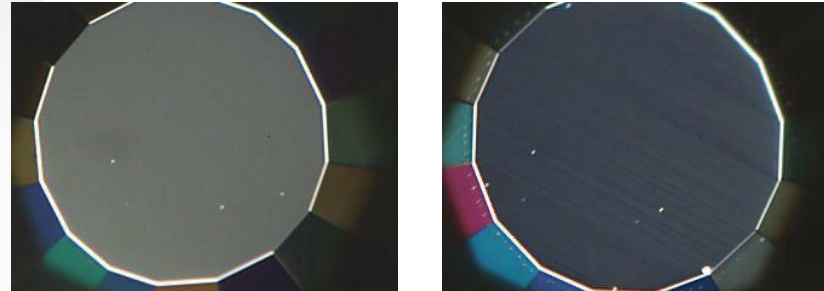

## Diamond cutting capabilities

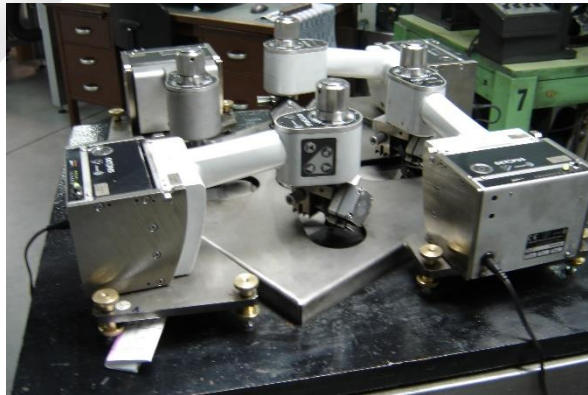
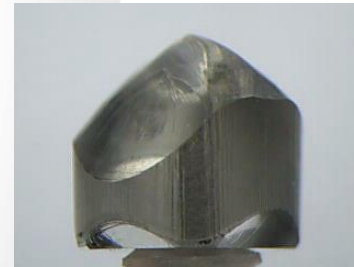



## Diamond cutting capabilities

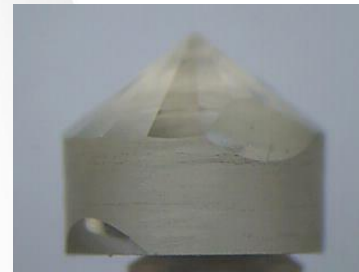
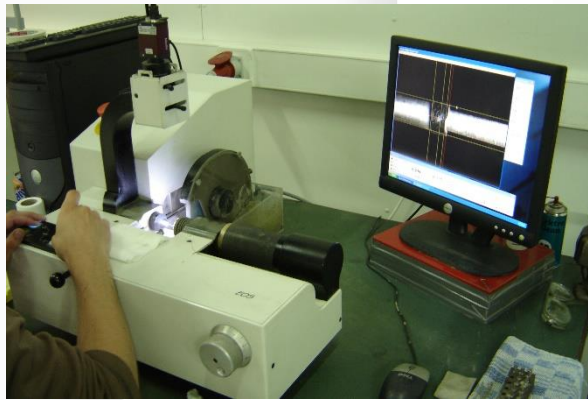

## Diamond specials

(PARTIAL) PERFORATIONS:

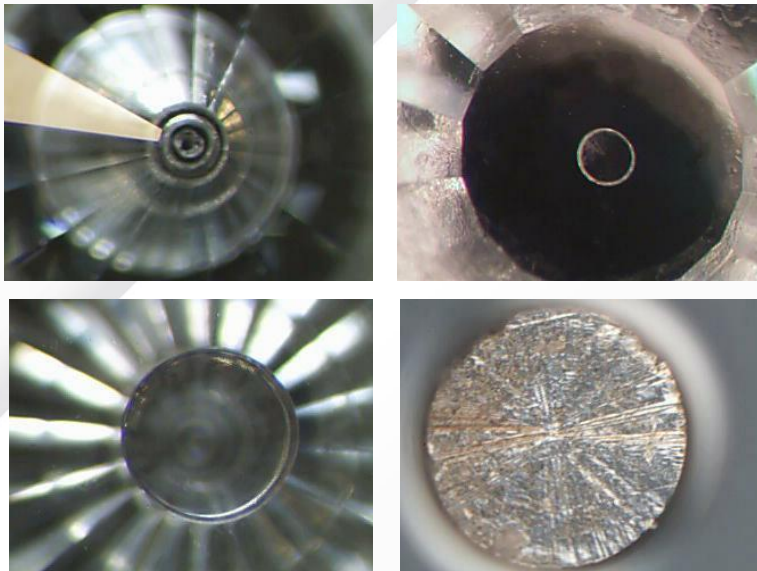

Less absorption  
 (small diamond anvils  
 on top)

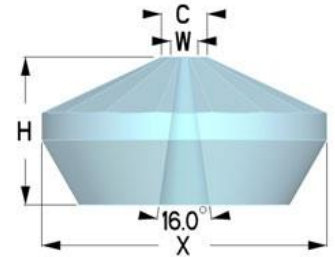

Less absorption

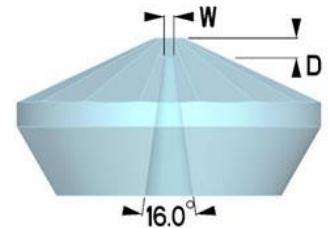

Larger sample volume

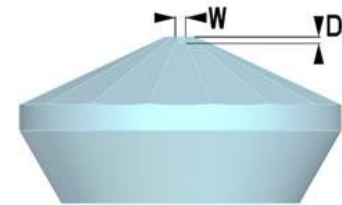

## Diamond specials

### ULTRA THIN DIAMOND WINDOWS:

- Minimum thickness: 10  $\mu\text{m}$
- Thickness tolerance:  $\pm 1 \mu\text{m}$
- Parallelity  $< 1 \mu\text{m}$
- $(100)$  or  $(110)$  oriented
- Sizes: depending on the required quality, up to 8.00 x 8.00 mm
- Applications: shock wave windows, diamond detectors, NV center research beam optics, ...

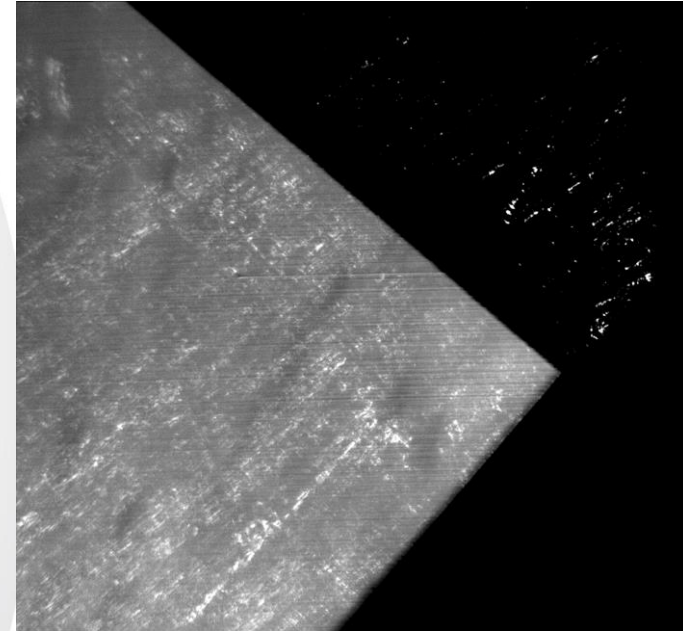

## Diamond specials

### PATTERNED DIAMOND ANVILS:

- Gold coated electrodes
- Default configurations:

$C=0.40$ ,  $C_b=0.45$ ,  $8^\circ \Rightarrow$  4 electrodes with interdistances of  $100 \mu\text{m}$

$C=0.80$ ,  $C_b=0.85$ ,  $8^\circ \Rightarrow$  4 electrodes with interdistances of  $200 \mu\text{m}$

No fiddling with wires

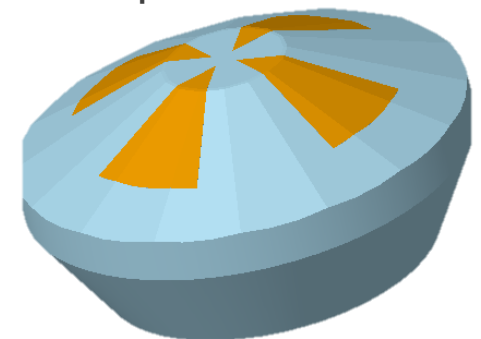
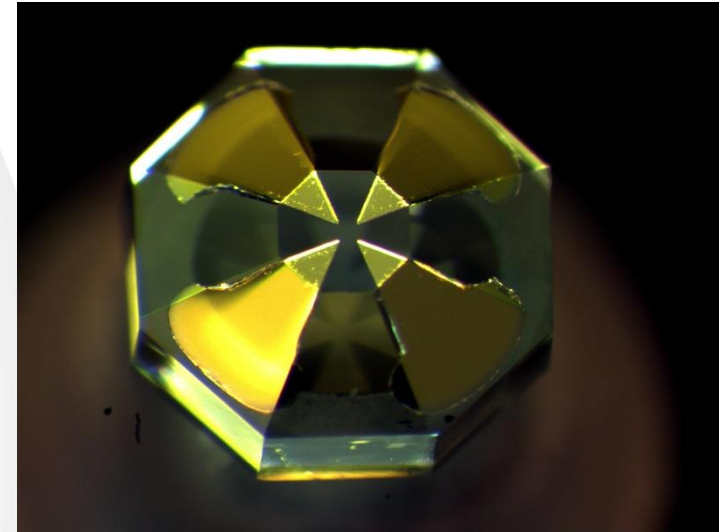

## Diamond specials

### PATTERNED DIAMOND ANVILS:

Before pressure run

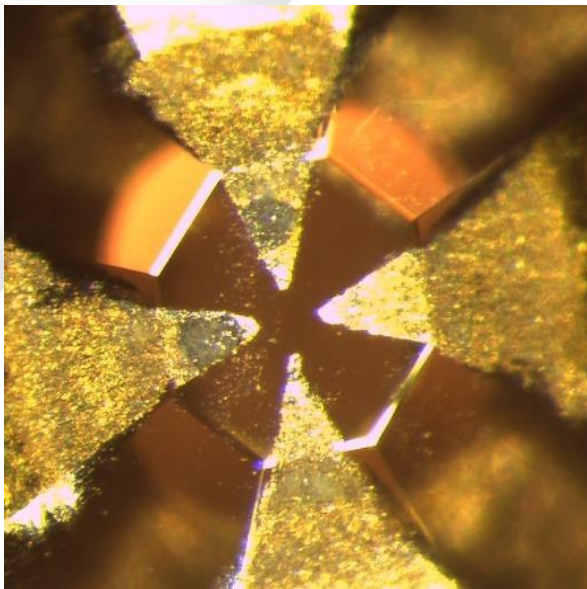

After pressure run up to 10 Gpa  
=> REUSABLE

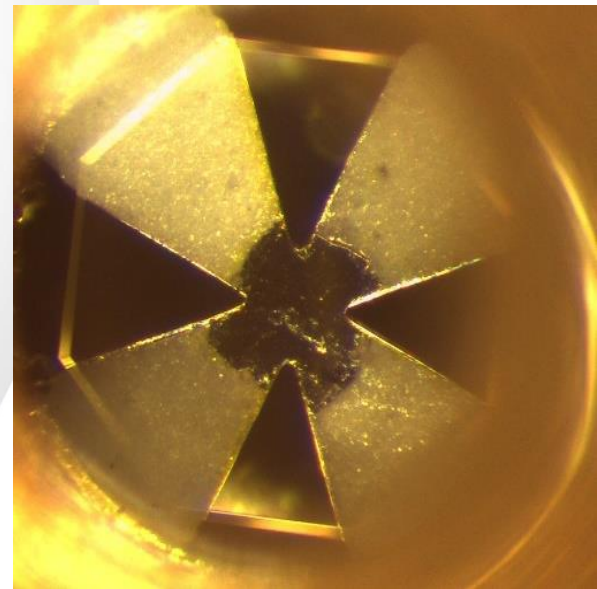

## Diamond specials

### INTELLIGENT DIAMOND ANVILS:

- Embedded tungsten electrodes (collaboration with UAB)
- Default configurations:

$C=0.25$ ,  $C_b=0.35$ ,  $12^\circ \Rightarrow$  8 electrodes with interdistances of  $60 \mu\text{m}$

No fiddling with wires

No gasket insulation required

Wires do not break under high pressure

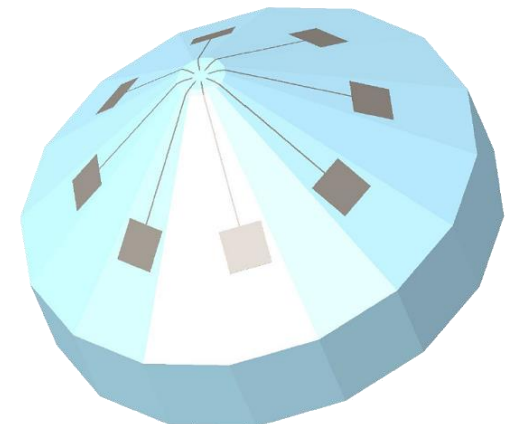
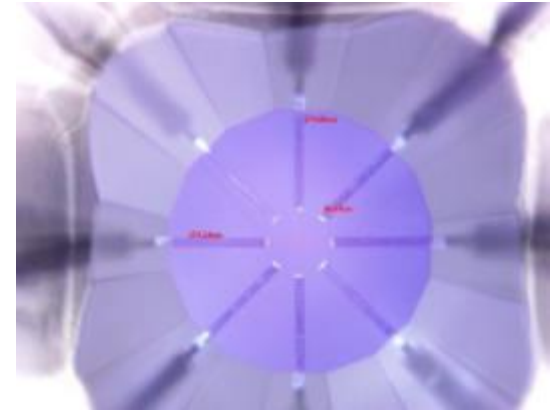

## Diamond specials

NV CENTERS for : quantum sensing, quantum positioning, quantum computing

*“The Nitrogen Vacancy (NV) center is a defect formed in diamond by one substitutional nitrogen atom and an adjacent vacancy. The NV forms a ground state spin triplet that can be controlled coherently at room temperature using electromagnetic fields.”*

Several HP groups are currently working on NV-centers-diamond optical magnetometry.

+ very high sensitivity

+ very high resolution

Meissner effect? NMR at HP?

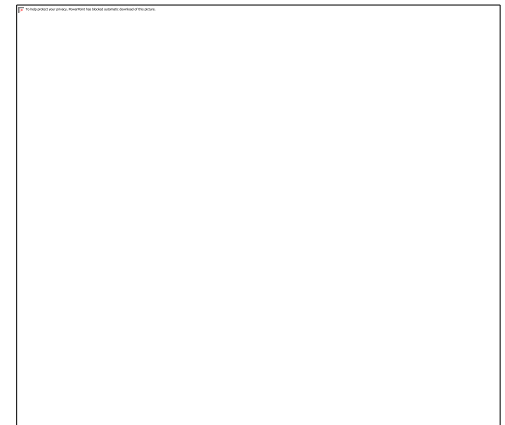

## Diamond specials

Smaller anvils for less X-ray absorption

$X=1.00$ ,  $H_{tc}=0.48$ ,  $C=0.25$

=> 65 -70 GPa



In Situ Viscometry of Primitive Lunar Magmas  
At High Pressure and High Temperature

$X=1.50$ ,  $H_{tc}=1.50$ ,  $x=0.50$

=> 1.10 - 2.20 GPa

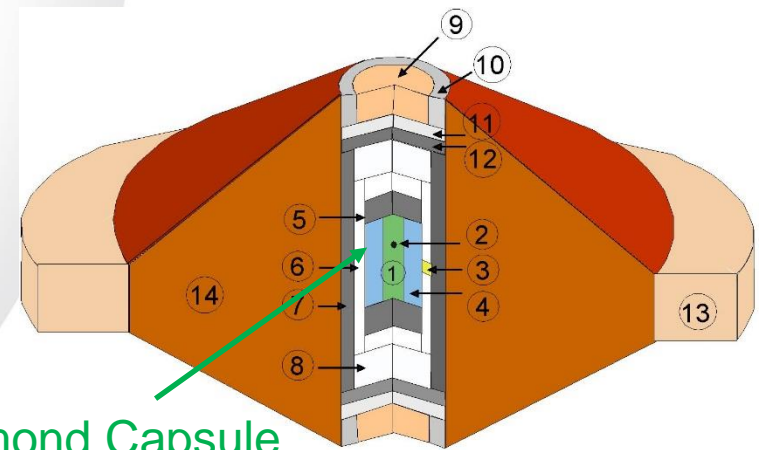

Diamond Capsule



## Diamond specials

STATIC PRESSURE RECORDS

DOUBLE STAGE DIAMOND ANVILS => 770 GPa

TOROIDAL CULETS => 615 GPa

FIB milling of toroidal culets.

250  $\mu\text{m}$  thick Re gaskets preindented to 4-5  $\mu\text{m}$

Gaskethole of 3-5  $\mu\text{m}$  in 9  $\mu\text{m}$  preindented area

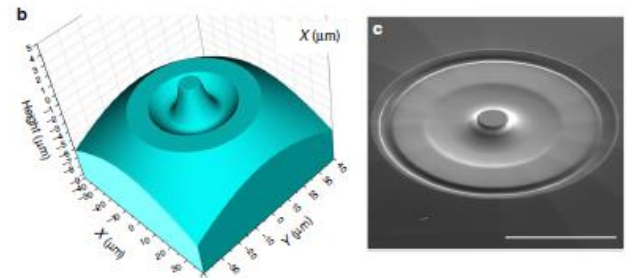
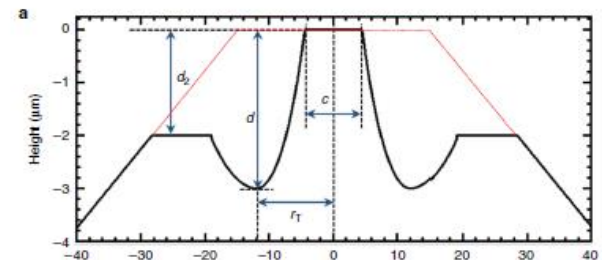
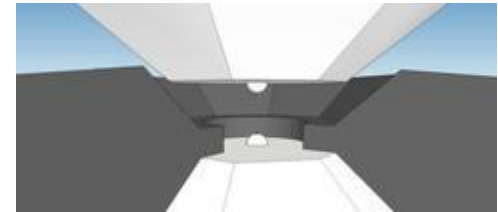

## How we interact with our customers: our projects

We work mainly on 3 types of projects

- **Standard:** Catalogue items – everything which is available on our website;
- **Modified Standard:** Based on the Standard but might need some modifications;
- **Customs:** Does not exist and we work with our customers towards a customised solution.



**Standard**

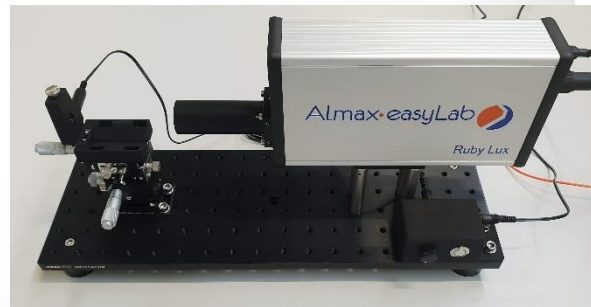

**Modified Standard**

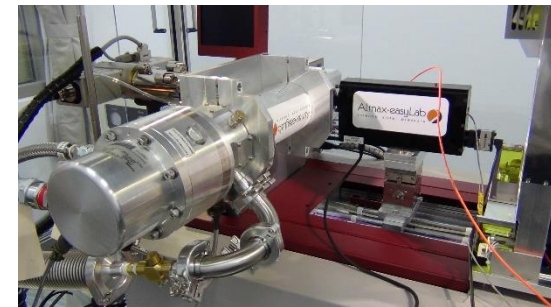

**Custom**

## Applications and measurement techniques

- Our products cover a wide range of measurement techniques: Magnetic, Electrical Transport, Optical (Raman, FTIR, Fluorescence,...), X-Ray (Lab diffractometers, Beamlines,...)
- Two main techniques for high pressure cells:
  - Piston cylinder high pressure cells: larger volume (typically few mm but max P limited to 30kbar – 3GPa. Often used for magnetic and electrical transport measurements);
  - Diamond anvil high pressure cells: smaller volume (typically 10s to few 100s of microns but max P much higher, 100GPa+).

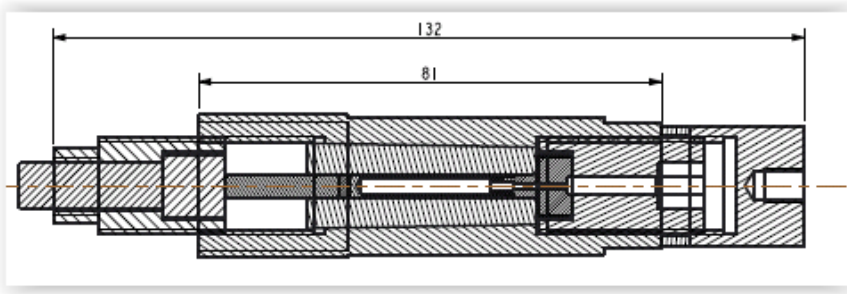

**Piston Cylinder**

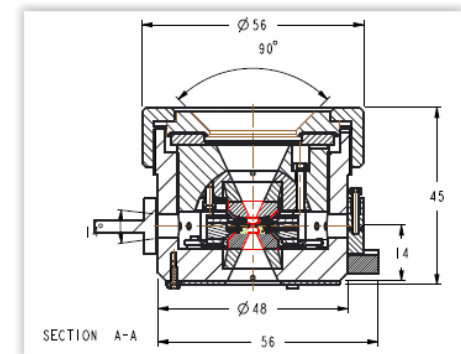

**Diamond Anvil Cell**

## Applications and measurement techniques: Magnetic measurements

- This type of pressure cells is used in conjunction with SQUID magnetometers which have sufficient sensitivity to measure small magnetic moments;
- Particularly suitable to study magnetic or superconducting transitions: anti-ferromagnetism, ferromagnetism or superconductivity;
- Particularly good to see anomalies (transitions) in  $M$  vs  $T$  or  $M$  vs  $H$  curves;
- Can be limited in terms of absolute magnetisation measurements as large magnetic background from the cell. 2 steps measurements: empty cell measurements (background) then cell + sample and background subtraction.

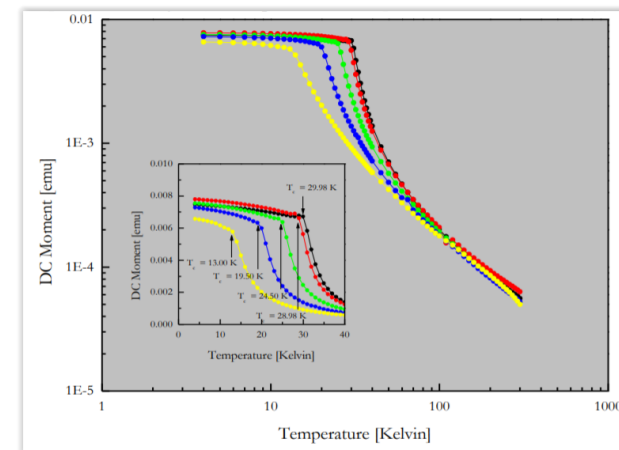
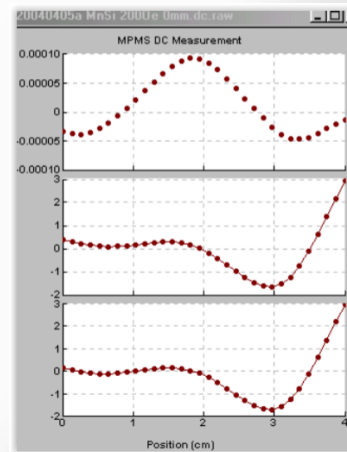
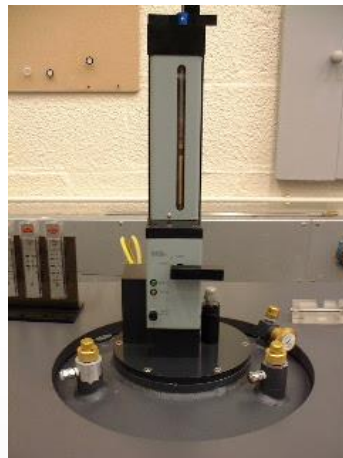

## Applications and measurement techniques: Electrical Transport

- This type of pressure cells is used in conjunction with cryostats to be able to carry out temperature or magnetic field sweeps and studies;
- The piston cylinder type cell gives more flexibility for measurements as enables resistivity, magneto-resistance or Hall effect measurements;
- Carrying out transport measurements in DACs is more difficult with the difficulty of getting the electrical wires to the sample in the gasket hole (gasket insulation, very small sample size and difficulties of sample contacts);
- Our patterned diamond anvils and newly introduced i-diamonds should help making this technique more accessible.



Electrical



Pressure cells suitable for electrical measurements to be mounted on cryostat for low temperature applications.

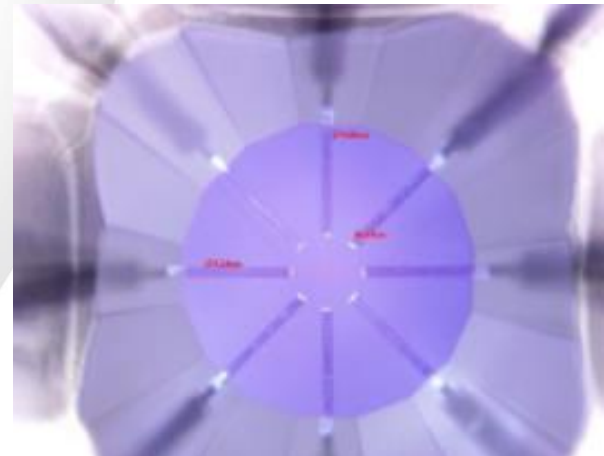

## Applications and measurement techniques: Optical Spectroscopy

- This type of pressure cells is used in conjunction with home made or commercial Raman or micro-Raman spectrometers;
- Working distance and available space is often limited to fit under short WD objective;
- Yet our DACs are designed to allow gas membrane control and even high temperature (up to 1000C by resistive internal heater).



Optical



We offer a wide range of diamond anvil cells for fluorescence, Raman and FTIR measurements. Low and very high temperatures options are available.

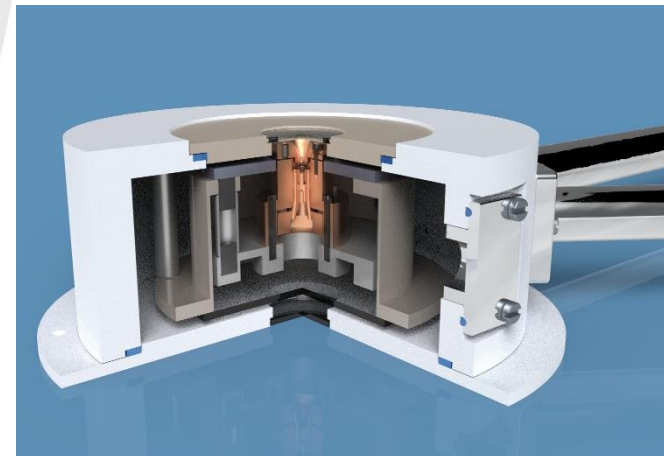
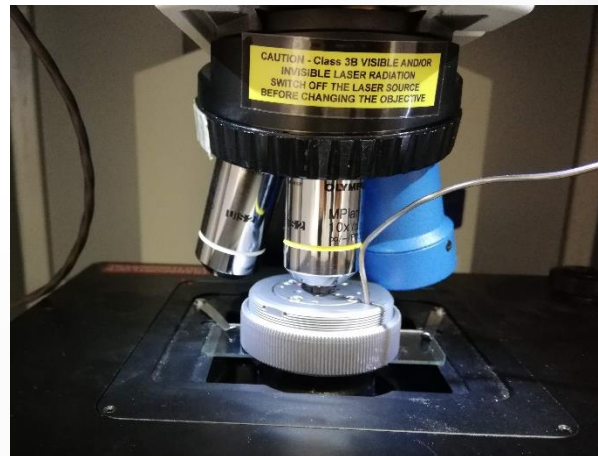

## Applications and measurement techniques: X-Ray Spectroscopy

- This type of pressure cells is used in conjunction with either laboratory X-Ray systems or mounted on synchrotron beamlines;
- The challenge is often to offer the largest possible apertures for wide angle collection;
- As an example we have developed the One20DAC offering an 120 degrees X-Ray aperture with the use of Boehler-Almax anvils of large diameter (4mm) and limited thickness (1.20mm).

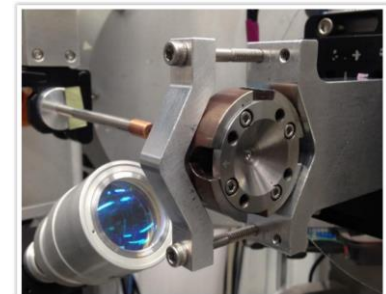
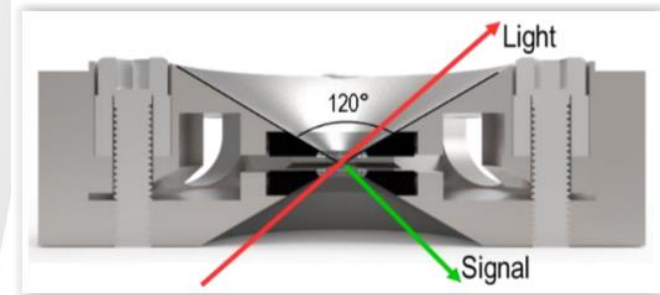

Various diamond anvil cells suitable for beamlines or laboratory X-Ray diffractometers.

## Sample Preparation: EDM Drilling

- Gasket material choice, quality and dimensions of the pre-indentation, quality of the drilled hole are often crucial factors for the good success of high pressure experiment with a DAC.
  - Gasket material depending on experimental conditions: Room Temperature=> Steel, Inconel, High Temperature or very high pressure=> Rhenium;
  - Thickness influences greatly the maximum pressure one can reach: Rule of thumb thickness around 10 to 20%, hole size around 35 to 50% of the culet size.
- Our Boehler uDriller provides a straightforward and automated solution to EDM holes from 1mm down to 40 microns) - We also provide a popular service of gasket drilling



High-accuracy automated electro-discharge machine for optimum drilling of metallic gaskets used in DACs. Spares and accessories also available.

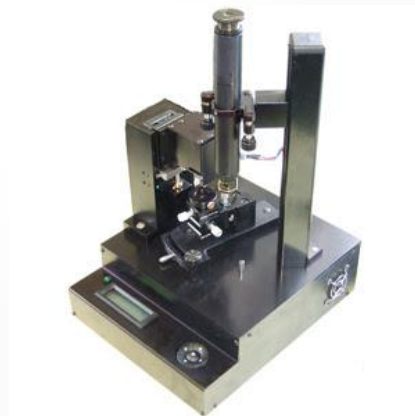



## Pressure measurement: Optiprex PLS and RubyLUX

- Our RubyLine is made of mainly two variants: The Optiprex PLS and the RubyLUX
  - Optiprex PLS: for benchtop use. Green or blue laser and standard or high resolution spectrometers;
  - RubyLUX: to be mounted on microscope, XYZ stage for breadboard use or to measure the pressure of low temperature DACs (through optical windows of a cryostats for example).

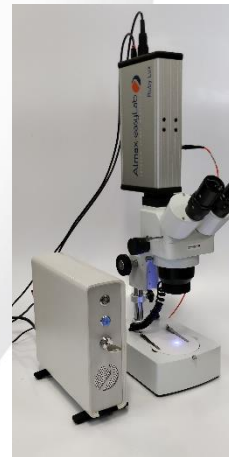
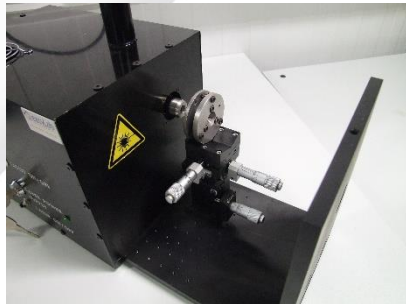

Rubyline



A range of optical systems to measure the pressure based on the Ruby shift. Our ruby measurements systems can be bench or microscope mounted.

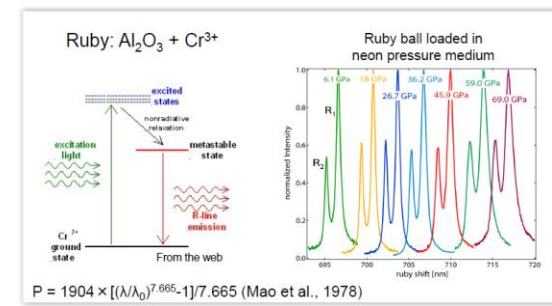

## Supporting Softwares: High Pressure Manager and Temperature Manager

- We are developing some Labview based executable softwares to enable remote control and automation of the measurement;
- High Pressure Manager controls the Ruby measurement, the Gas controller (iGM) and the observing Ruby camera;
- Temperature Manager controls the power supply and thermocouple reader for high temperature experiments.

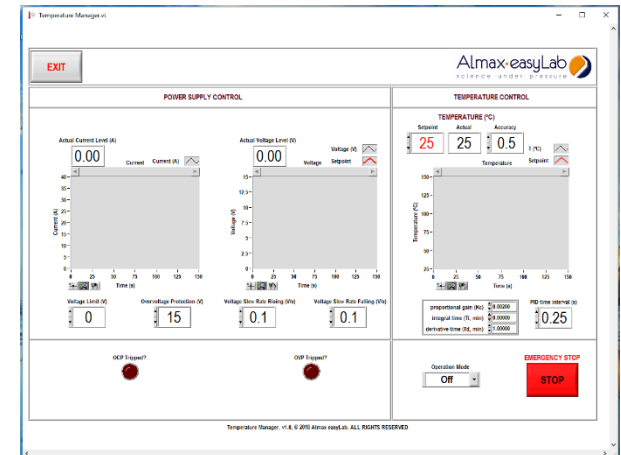
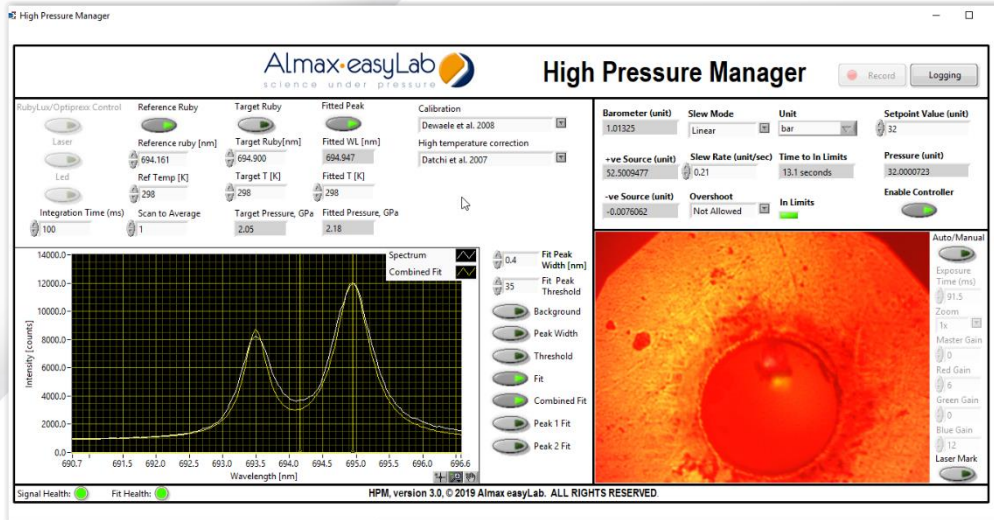

## Future

Automation of your HP experiments with software controlling the devices and storing the data captured during the pressure run.

=> No longer performing the experiment, but rather analyzing the data.

Synthetic diamond anvils will replace natural diamond anvils.

As HP becomes more and more “plug-and-play” it becomes an every day tool in the lab.

NV center based measurements with diamond anvils is still challenging but we expect it to open up new possibilities within HP.

**Thank you for your attention!**

**QUESTIONS?**