

Specificity of Magnetic Measurement for Insertion Devices

Pascal Elleaume, ESRF

Technology of Undulators and Wigglers

- The goal of an insertion device is to produce a sinusoidal planar field with a **high peak field** (0.5-2 T) and the **shortest period**.
- Such a high gradient is best provided by **permanent magnets**
 - The Material used is :
 - NdFeB (Br =1.2-1.4 T)
 - $\text{Sm}_2\text{Co}_{17}$ (Br = 1.05 T) (less sensitive to Temperature and Radiation Damage)
 - The magnetic field is tuned by changing the magnetic gap between the upper and lower arrays of magnet through a high resolution high strength mechanical structure.
- Room temperature electromagnet technology is some times used for long period undulators.
- Superconducting technology is used for high fields (> 2 T) with a period shorter than those available from permanent magnets.

Hybrid

+ higher field

Pure Permanent Magnet

+ simple to compute and to correct

+ lowest cost

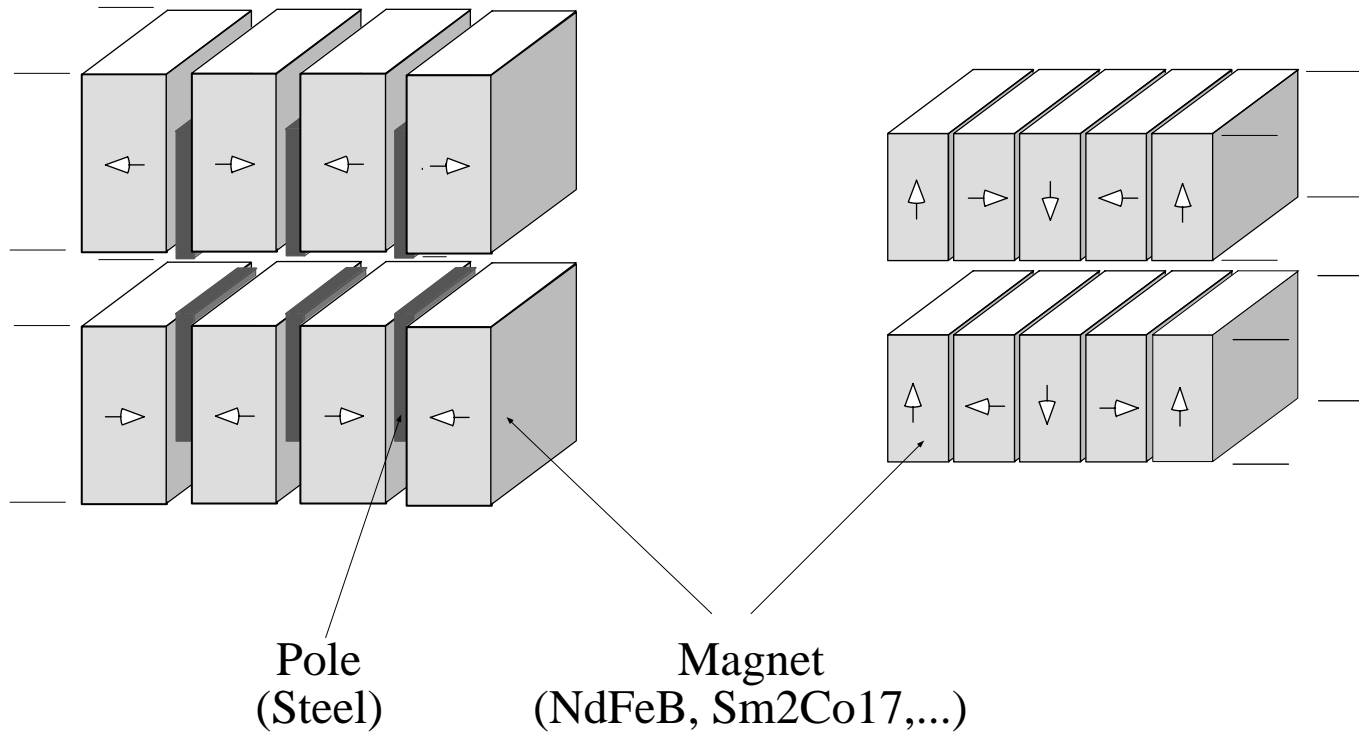

In Vacuum Permanent Magnet Undulators

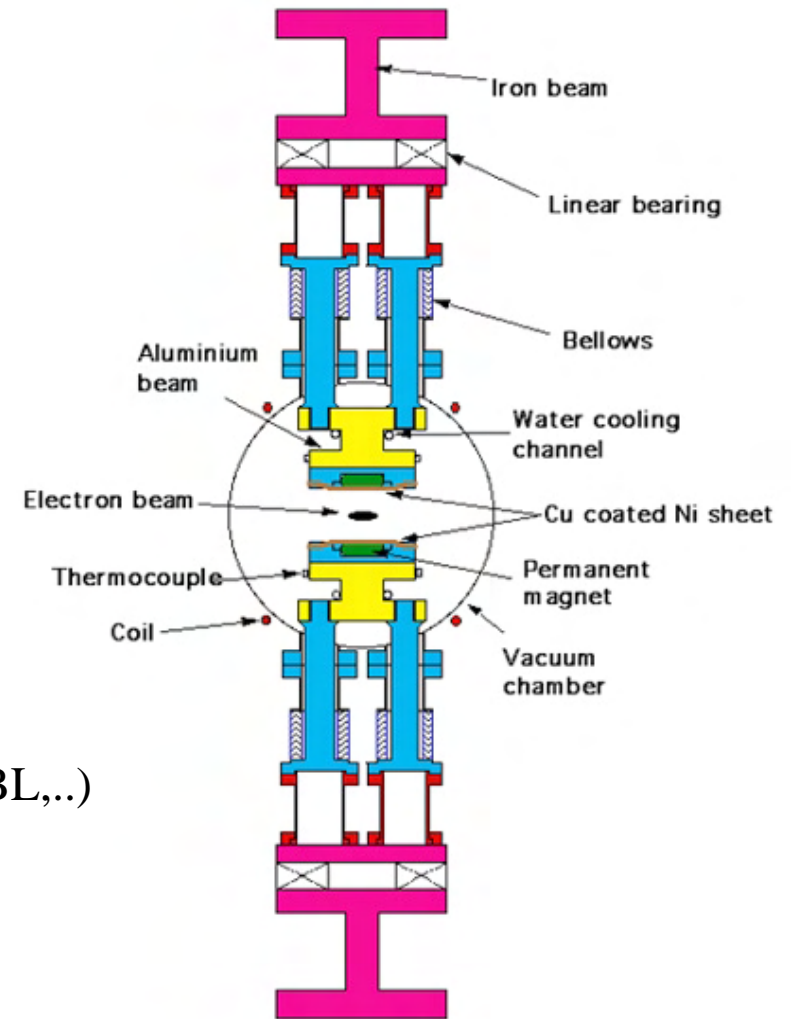
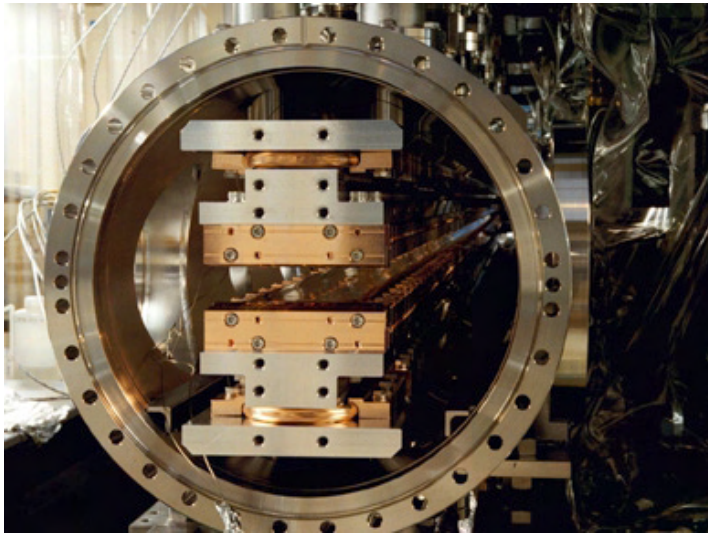

Spring-8 In-Vacuum Undulator

- Mostly Developed at Spring-8 (Japan)
- Becomes more and more popular (ESRF, SLS,CLS,LBL,..)
- Operating gap ~ 4-6 mm
- Usefull to reach high photon energies
- Usefull to reduce the required electron energy

Electro-magnet Wiggler

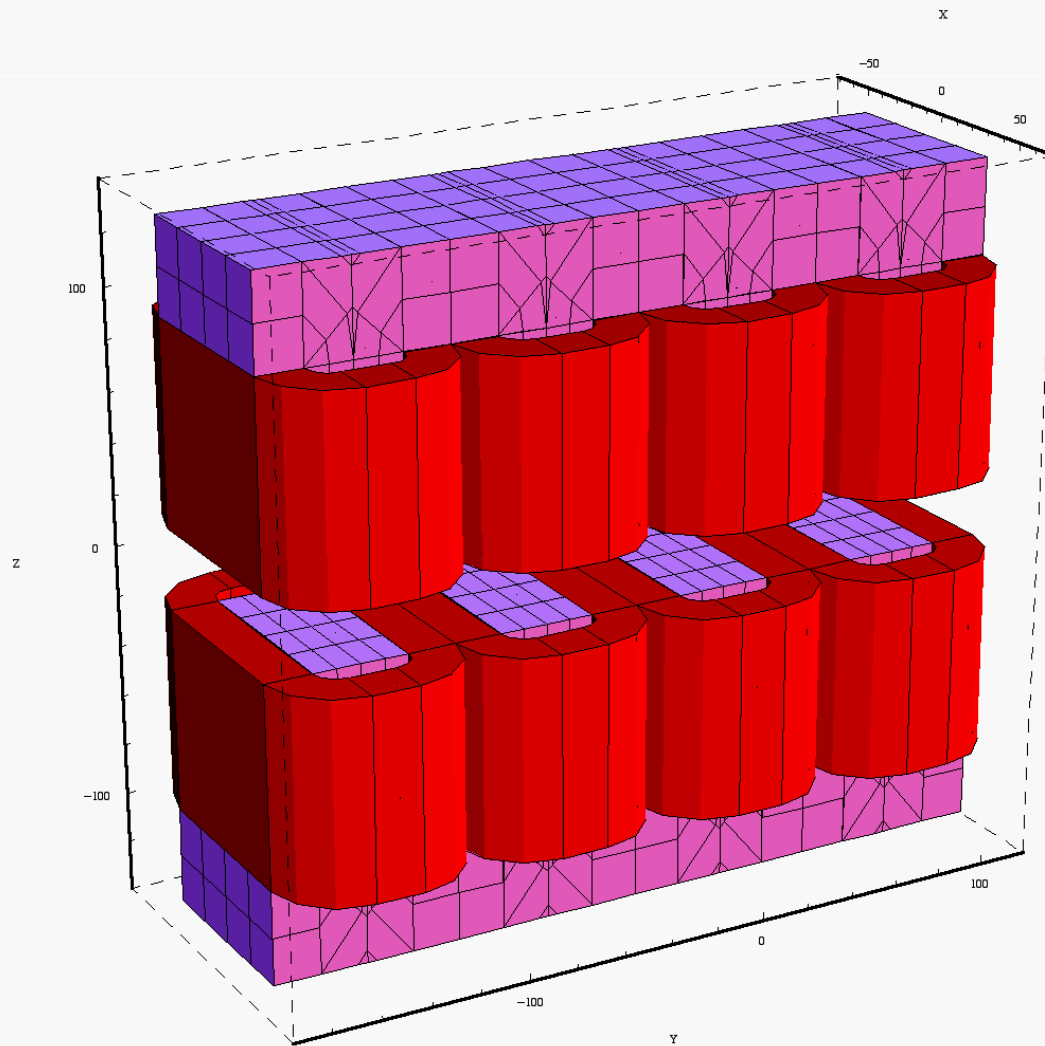

P. Elleaume, ESRF, IMMW-X11

Difference between a Wiggler and an Undulator

Typical **Undulators**

- Period 20-50 mm
- Field : 0.5-1 T
- gap 10-15 mm
- Length : 1-5 m
- Spectrum made of a series of peak

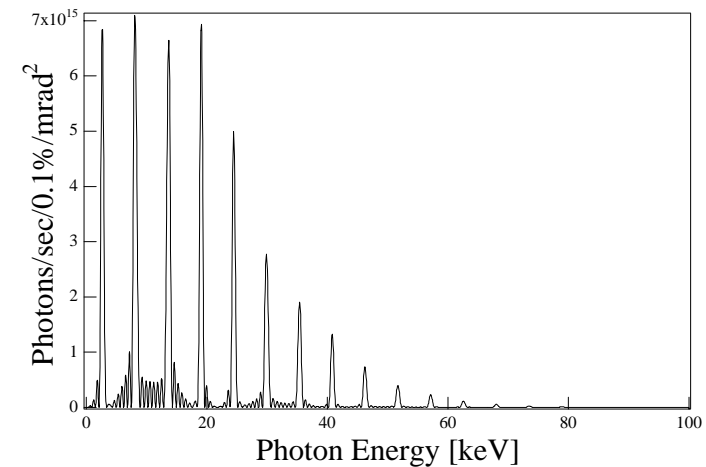

Typical **Wigglers** - Period > 60 mm

- Field : > 1 T
- Length : 1-2 m
- Continuous spectrum extending to high energies

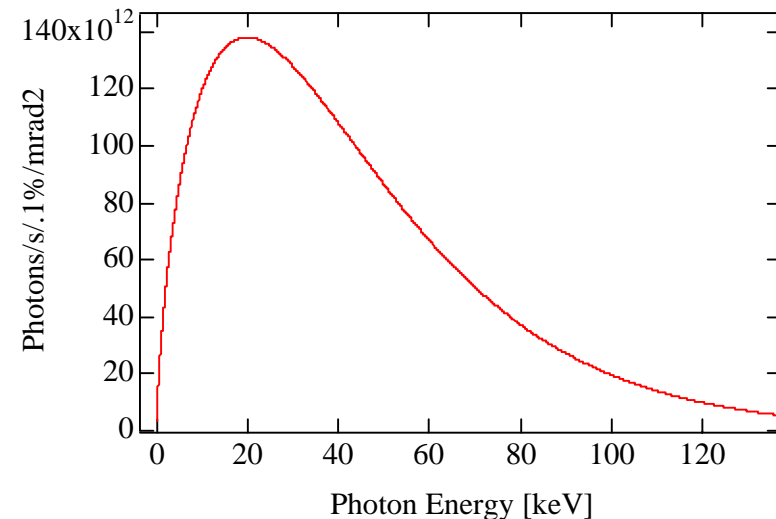

Magnetic Field Specifications

- To Minimise the perturbation to the stored beam :
 - Low integrated vertical and horizontal multipole for **any value of the peak field** (gap)
 - ESRF spec.

$$\text{Integrated Dipole} \quad \int_{-\infty}^{\infty} B_z, B_x ds < 20 \text{ Gcm}$$

$$\text{Integrated Skew Quad} \quad \frac{\partial}{\partial z} \int_{-\infty}^{\infty} B_z ds < 200 \text{ G}$$

- To Maximize the Spectral Properties
 - Small Phase Errors (~ 1-2 deg.)

Why phase shimming ?

Vertical Field vs longitudinal position

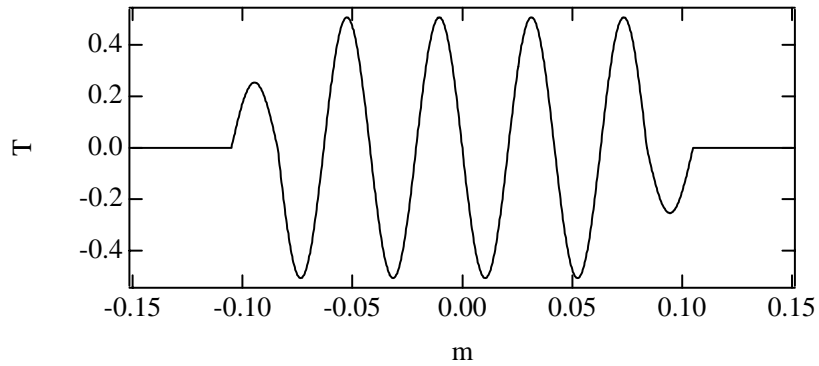

Horizontal Trajectory

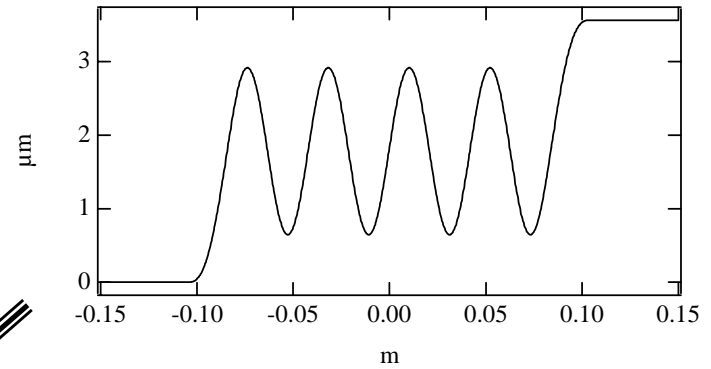

Horizontal Electric Field

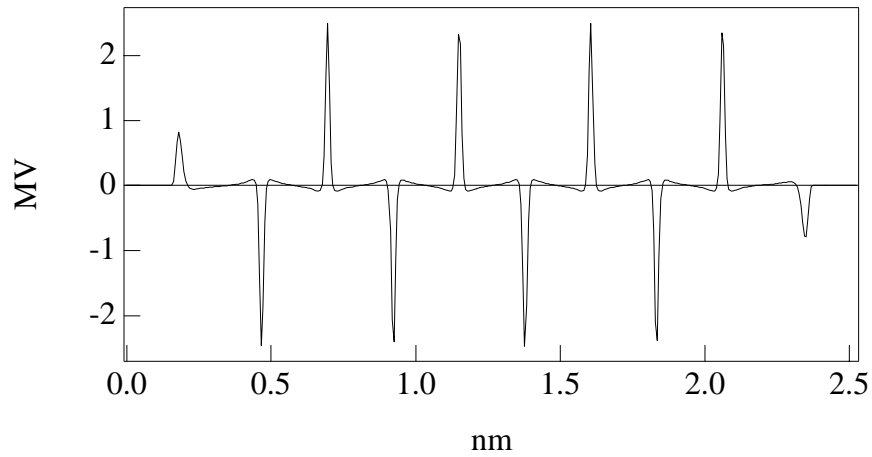

Power Spectrum

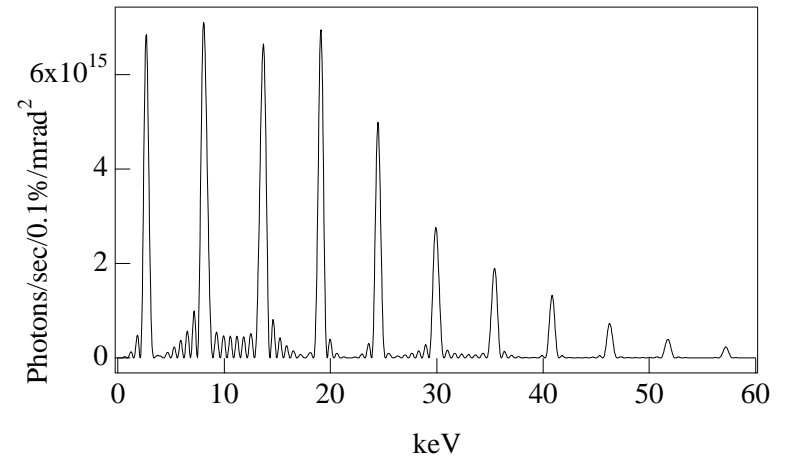

Generalities

Similarly to superconducting magnets, the field from permanent magnet insertion

devices is **not iron dominated**

⇒ Field quality does not reduce to machining tolerances.

⇒ Field errors comes from

- + Inhomogeneities of magnetization within the blocks
- + Error of positionning and /or orientation of the blocks

Magnetic field correction of an undulator made of 200-1000 blocks is made by **shimming** :

- + Time consuming
- + Not easy to automatize

Phase Errors

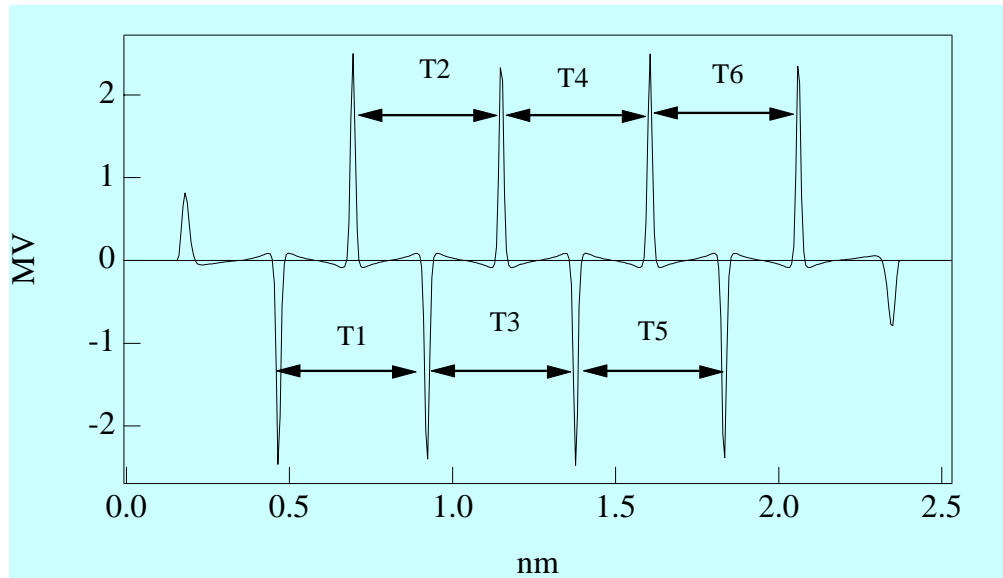

$$\text{Phase Error} = \varphi = 2\pi \frac{\sigma_T}{\langle T \rangle}$$

Induced by :

Peak Field fluctuations

Period fluctuations

Field Shape fluctuations

Example : ESRF Undulator

Period = 35 mm, B = 0.67 T, K = 2.2

1 deg. Phase error Corresponds to

0.2 % rms peak field fluctuation

Or 42 μm period fluctuation

$$\lambda_n = \frac{\lambda_0}{2n\gamma^2} \left(1 + \frac{K^2}{2}\right) \quad K = \frac{eB_0\lambda_0}{2\pi mc}$$

P. Elleaume, ESRF, IMMW-X11

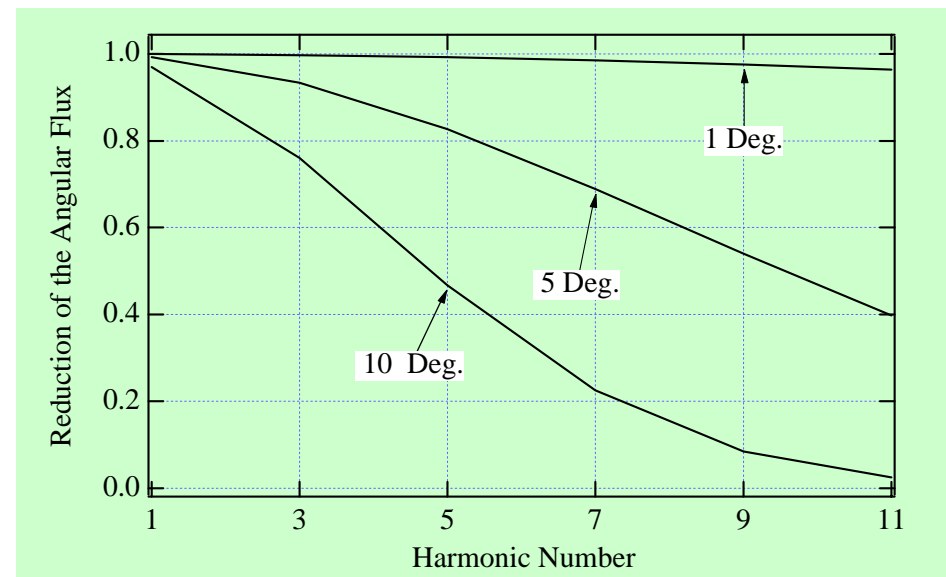

Undulator Shimming

- **Mechanical** : Moving permanent magnet or iron pole vertically or horizontally
 - Simple and efficient to correct Field Integrals
 - Inefficient to remove integrated multipole
- **Magnetic** : Add thin iron piece at the surface of the blocks
 - Field reduction

Magnetic Shimming

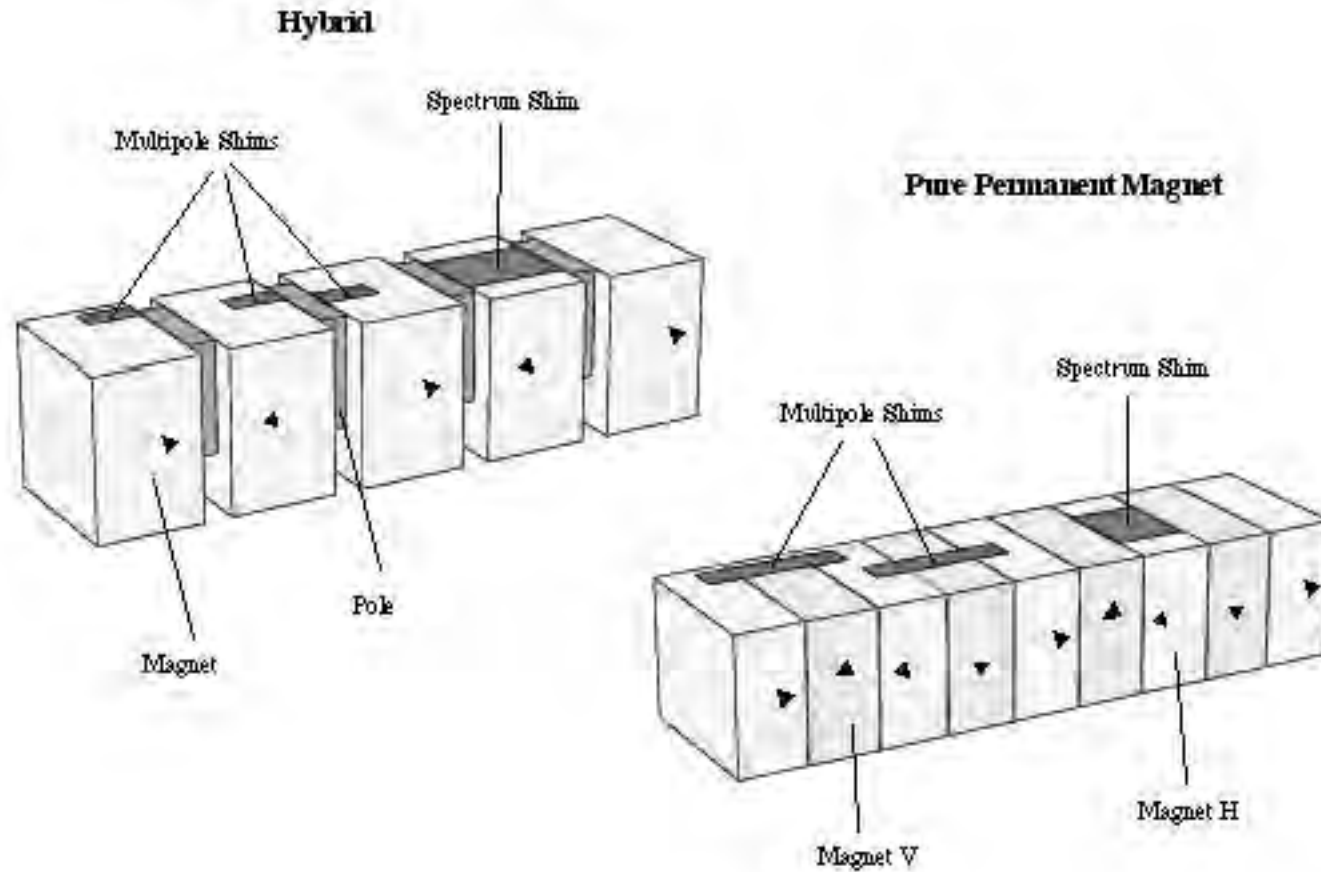

Undulators are Fundamentally **Small Gap** Devices

- Like any accelerator magnet, the smaller the magnetic gap the less volume of magnetic material required to reach a specify field geometry.
- The lower the gap the higher the energy of the harmonics in the undulator emission.

$$\lambda_n = \frac{\lambda_0}{2n\gamma^2} \left(1 + \frac{K^2}{2}\right)$$

$$\text{with } K = \frac{eB_0\lambda_0}{2\pi mc} = 0.0934 B_0[T] \lambda_0[mm]$$

- The most advanced undulators have magnet blocks in the vacuum with an operating magnetic gap of 4-6 mm

Three type of measuring equipments

- Characterization of the permanent magnet blocks
 - Total moment (By the manufacturer to fall within the spec)
 - Helmholtz + Integrator
 - Field Integral
 - Small coils + Integrator
- Local field measurement vs longitudinal coordinate using on-the-fly scanning Hall probes
- Field integral measurements vs horizontal position using long air coils and/or stretched wires

Variable Polarization Apple II Undulators

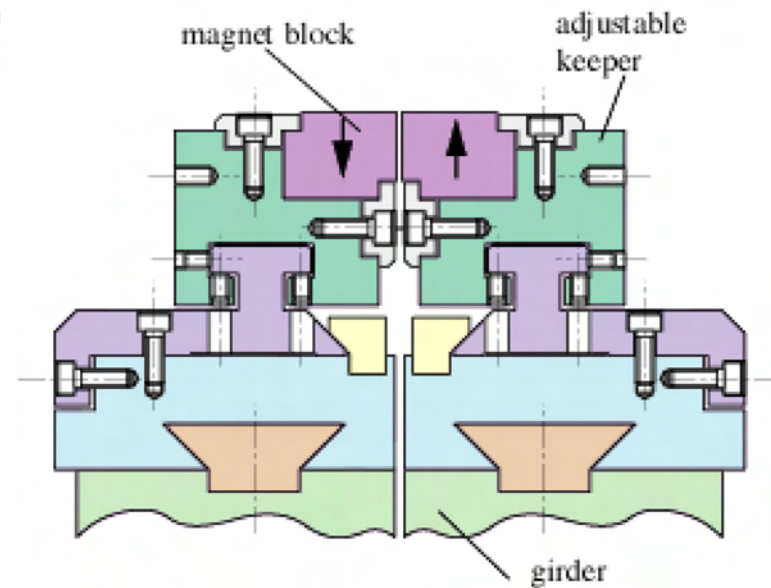
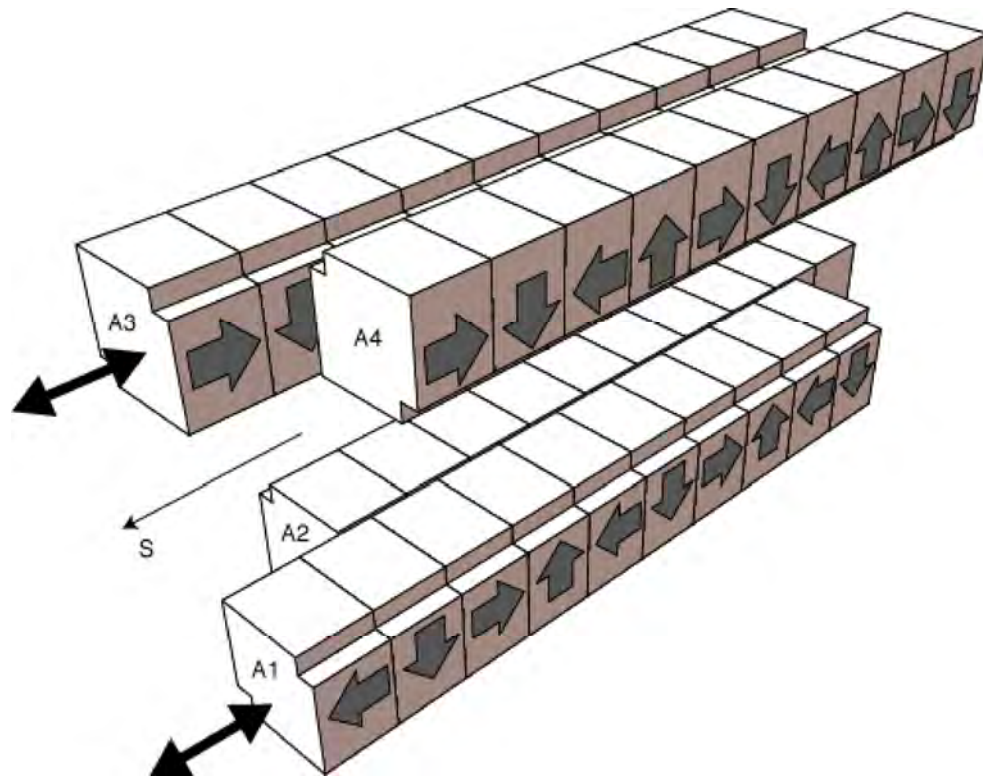

Scanning Hall Probe Measuring Bench

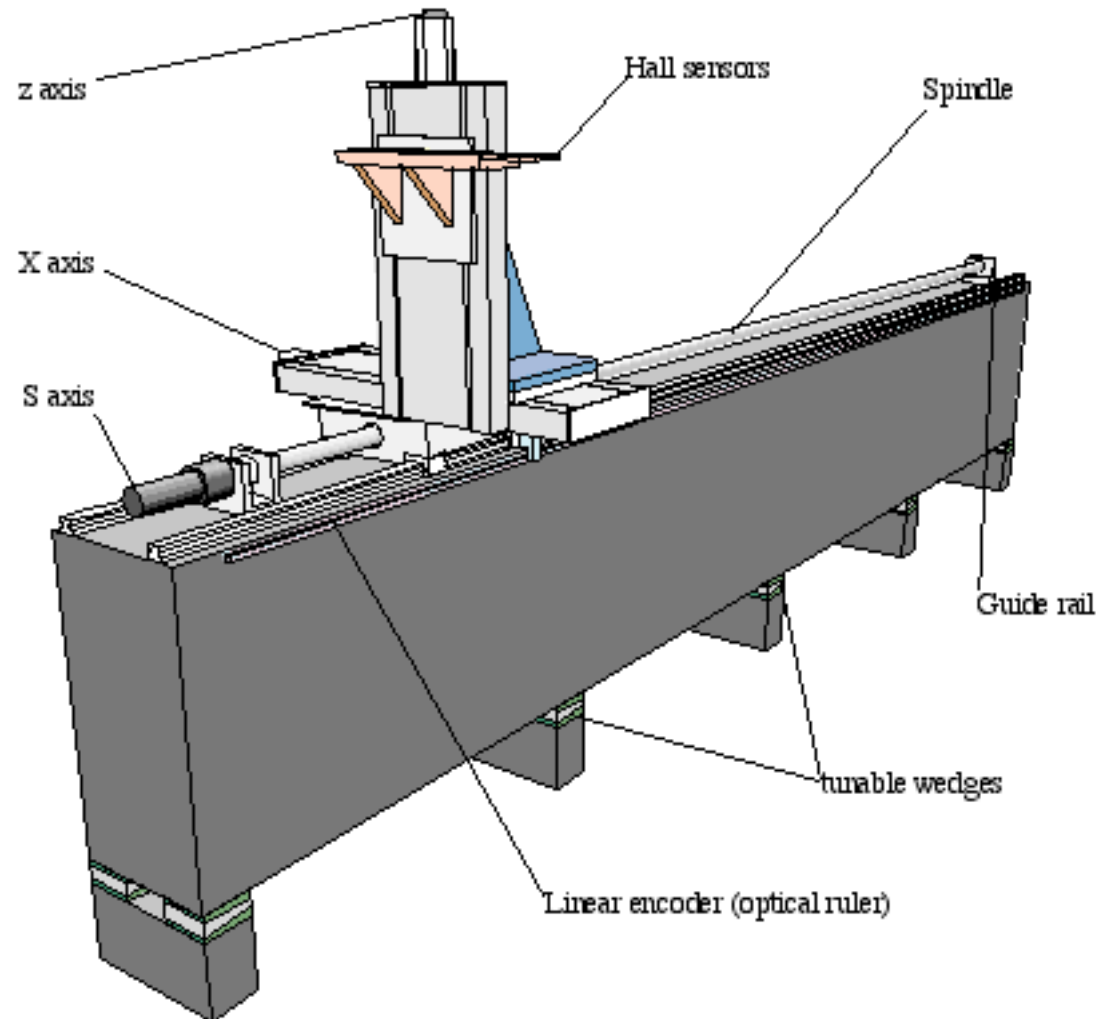

Remarks on Hall Probe measurements

- Narrow aperture Hall probe are needed
- On-the Fly scanning is essential to reduce the sensor vibration (precision) and to reduce the measuring time. Stop and Go methods are much slower and less precise.
- Precision of measurement can be very sensitive to the Planar Hall effects (Helical Undulator)
- One is more interested in an accurate measurement of the variation of the field from one point to the other than on the determination of the absolute value of the field
- Temperature stabilization of the probe and/or laboratory is in most cases unimportant as far as the temperature does not change during the measurement over the length of the undulator.
- Useful to measure all three components (helical undulator, planar Hall effect,...)

Field Integral Measuring Bench

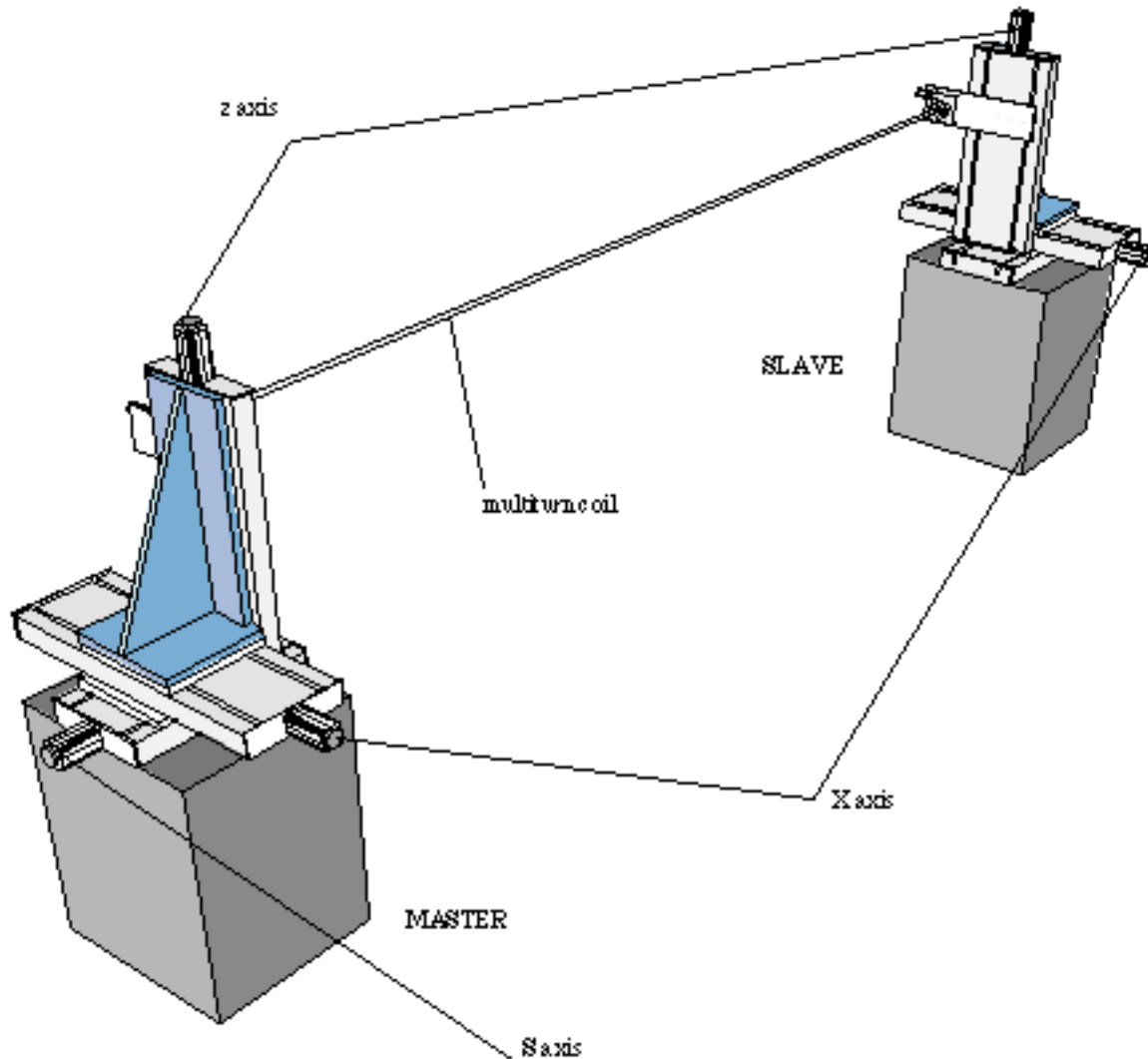

Remarks concerning Field Integral Measurements

- Conventional Harmonic Analysis cannot be performed because the transverse section available for field measurement is flat and not circular : 60 x 10 mm => small diameter coil => insensitivity to higher multipoles
- Determines higher order multipoles through a sequence of integrated dipole measurement at different horizontal position in the gap.
- Solid coils are useless due to the systematic errors that they introduced : one must use stretched wires (single or multi-turns).

Conclusion

- Obviously, the Magnetic field measurement of insertion devices **make use of the same technologies** developed for the conventional accelerator magnets (dipole, quad., sext...) : Hall Probe , Integrator & NMR
- The design of the Hall probe and field Integral measuring benches and the shimming processes are very **specific** to insertion devices.